



Hydrogen
For Health

Brown's Gas Therapy Machine v4.0

H2Life BGv4

User's Manual

Part List.....	3
BG4 Machine Diagram.....	4
Installation Manual.....	5
Operation Instructions.....	8
Troubleshooting.....	12
Maintenance.....	13
Warranty.....	17
Legal Disclaimer.....	18



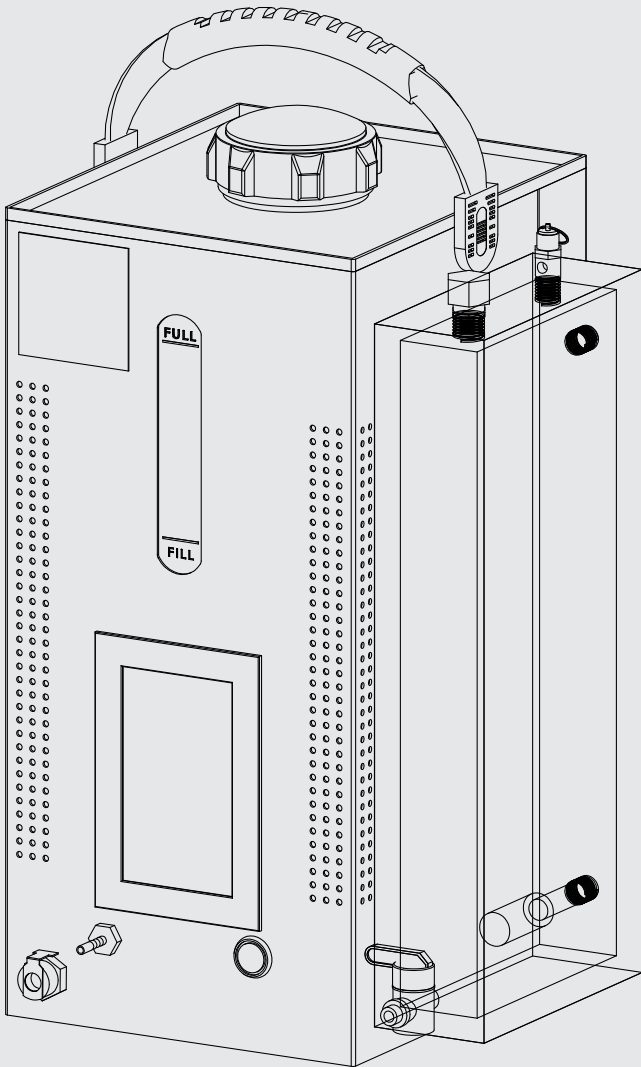

Brown's Gas Therapy Machine

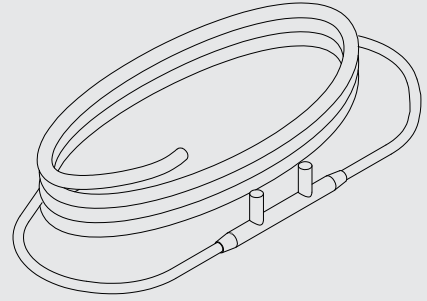

Cannula

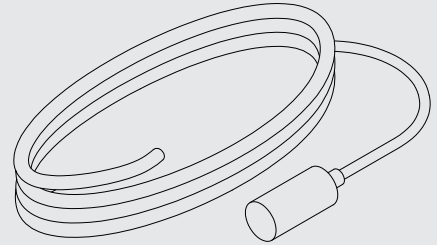

Stone Diffuser



Water Trap

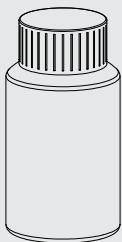

Bottle of Lye

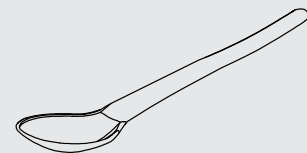

Measuring Spoon

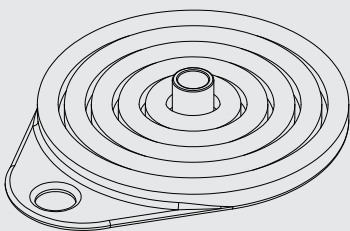

Collapsible Funnel

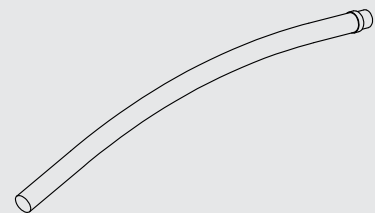

Drain Hose

Note

This system requires Distilled Water to operate which is not included. This item is available in most grocery stores. Reverse osmosis water, tap water, bottled water or any other kind of water will not work.



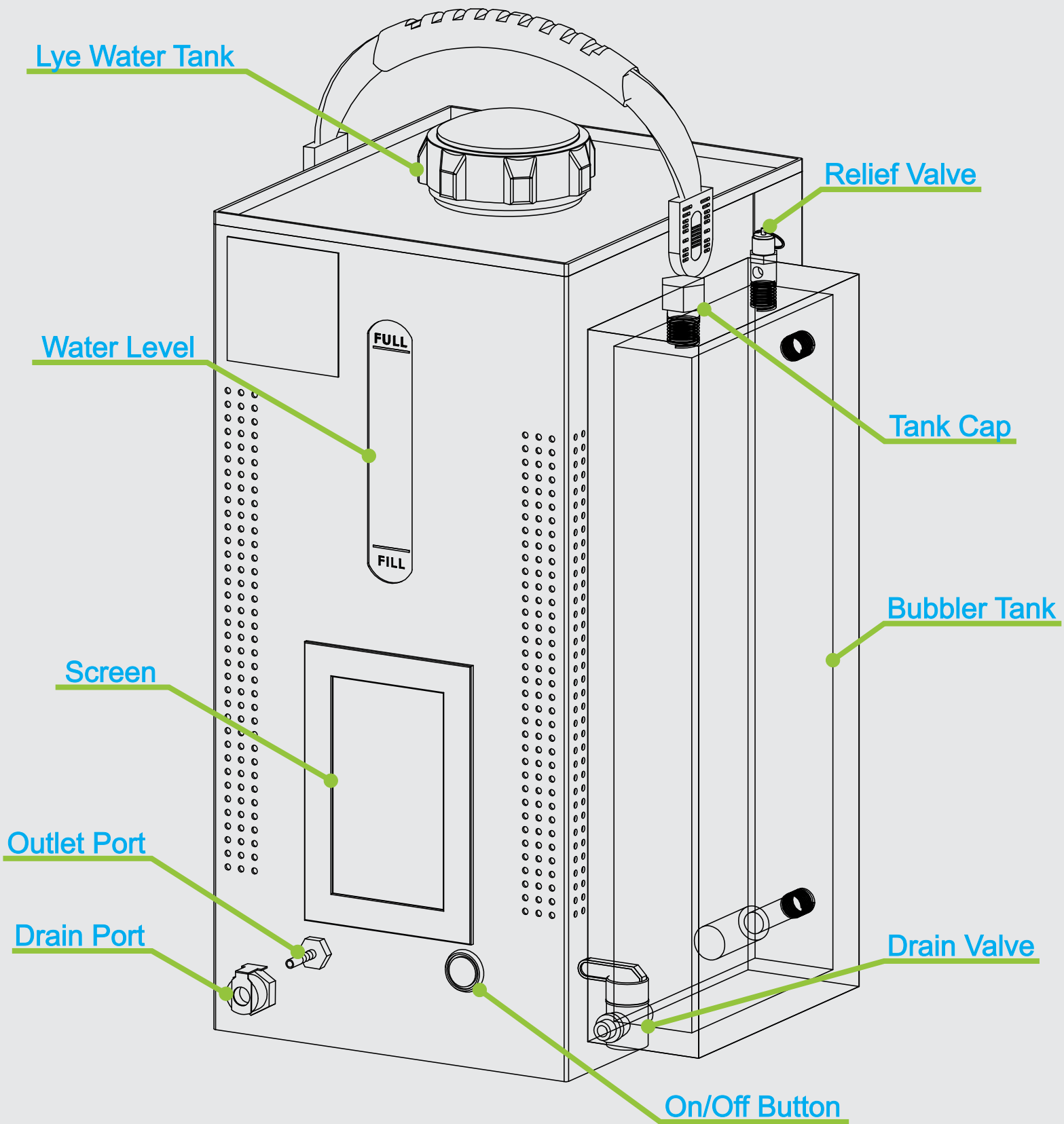

1

Perform a visual inspection of the machine. Look for any damage that may have occurred during shipping. Contact us if there is any damage to the machine or to any of the accessories. Our contact information is at the end of this document.

2

Open up the lye water tank cap, as shown below:

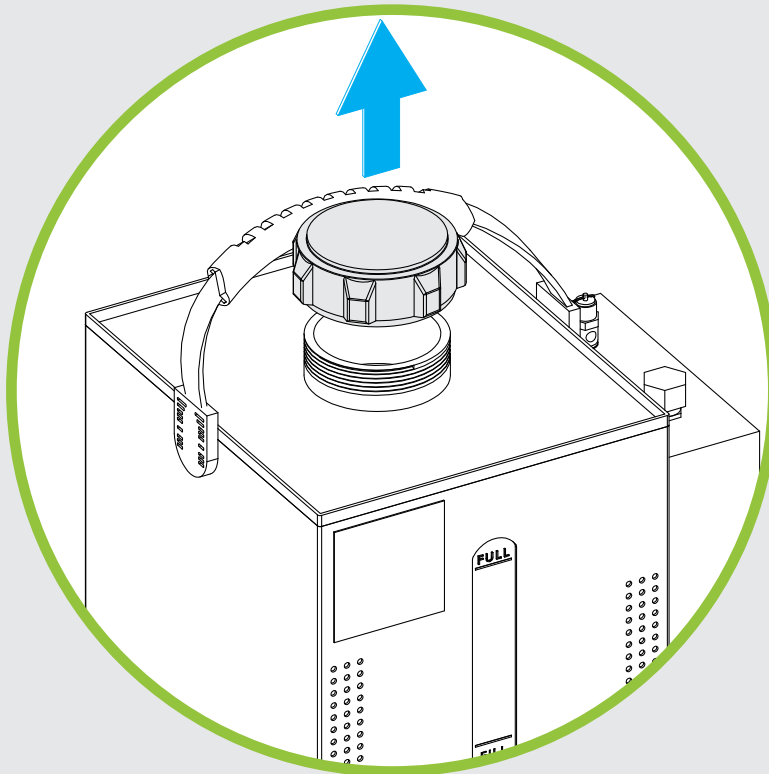

3

Deposit two spoon-fulls of lye into the Lye Water Tank. Use provided spoon for measuring. We suggest you also use a small cup to pour the lye into. So it's easier to fill up the spoon.

CAUTION

Lye's contact with skin can cause severe skin burns. Be careful when handling Lye. Use of nitrile gloves is recommended.

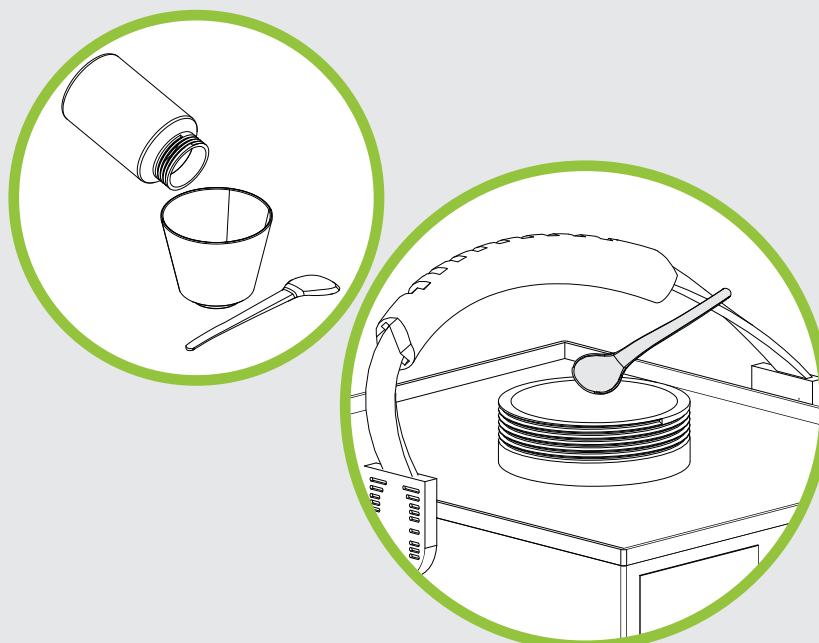

4

Fill up the Lye Water Tank with distilled water using provided funnel. Be careful not to overflow the tank. Pay attention to the water level indicator. Fill up to just below the full line.

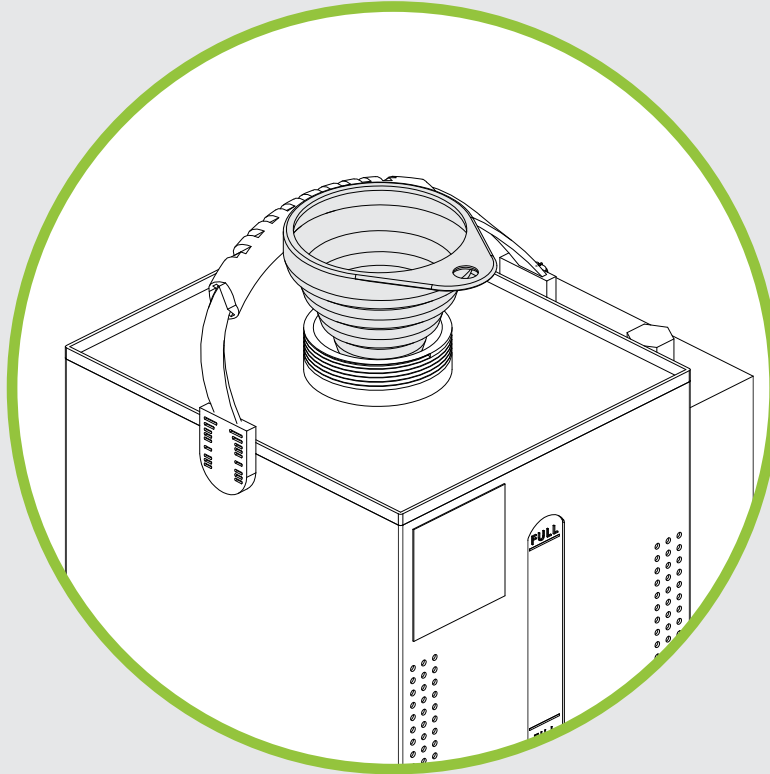

5

Put Lye Water Tank cap back in place. Make sure to tighten well.

6

Fill up Bubbler tank with distilled water by taking off the tank's cap. Make use of provided funnel. You may pull the tank's valve up so the tank fills up quicker.

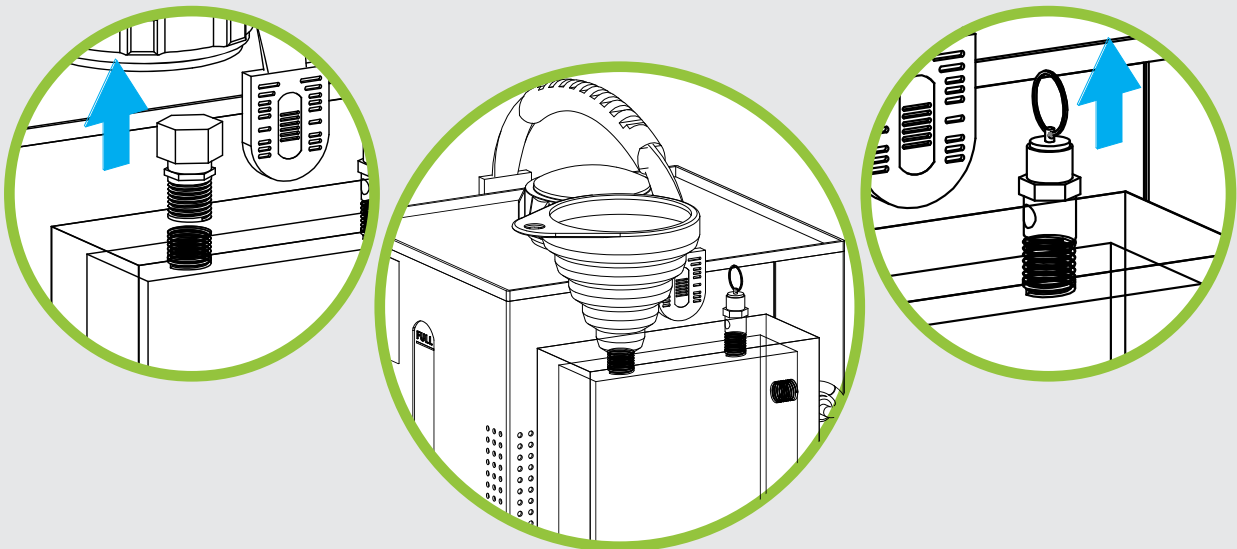

Note

Make sure the tank's valve snaps back down.

7

Put Bubbler Tank cap back in place. Make sure to tighten well.





1

Click on the “Time” button to change to the desired operation time. Dial in your desired operation time. Click on “ok” to confirm change.

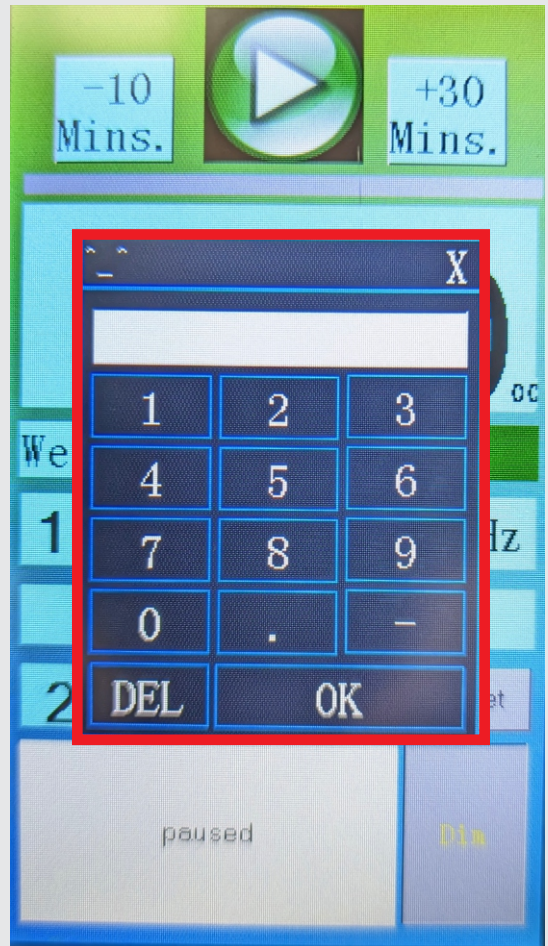

2

Click on the “Weight” button to dial in your weight. Click on “ok” to confirm change.

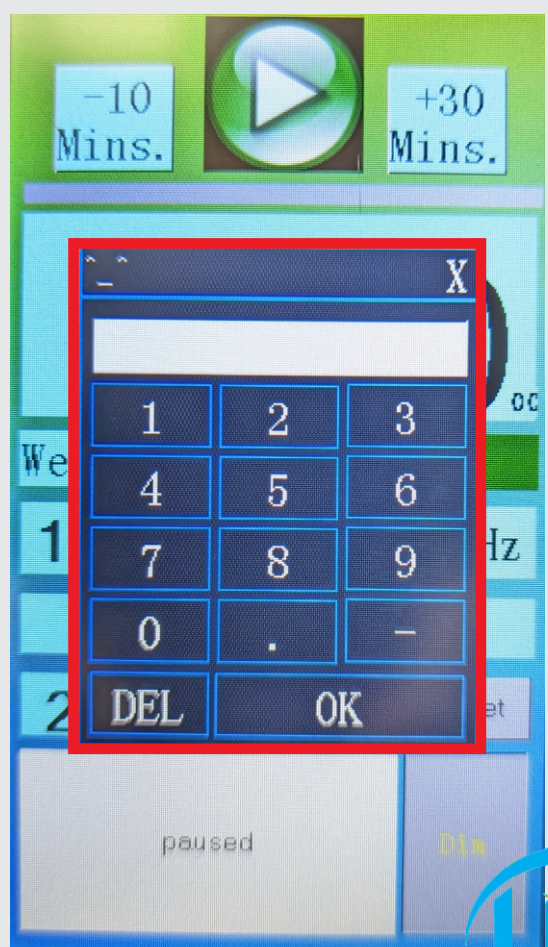

3

Click on the “Frequency” button to set the desired frequency.
Click “ok” to confirm changes.

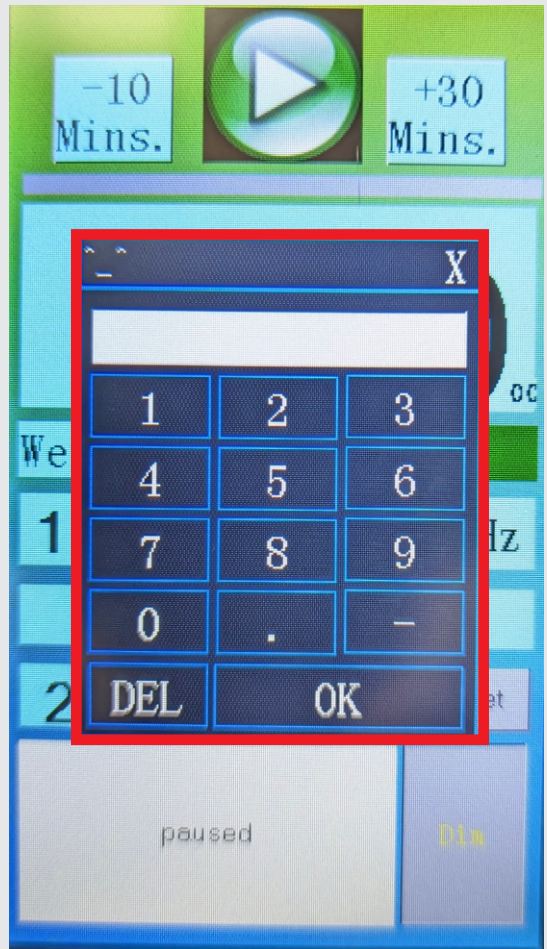

4

Start your inhalation session by pressing the play button.



5

Plug your choice of Nasal Cannula or Diffuser Stone into the outlet port as shown below:

Note

If diffuser stone is plugged in make sure to set the weight to 255lbs

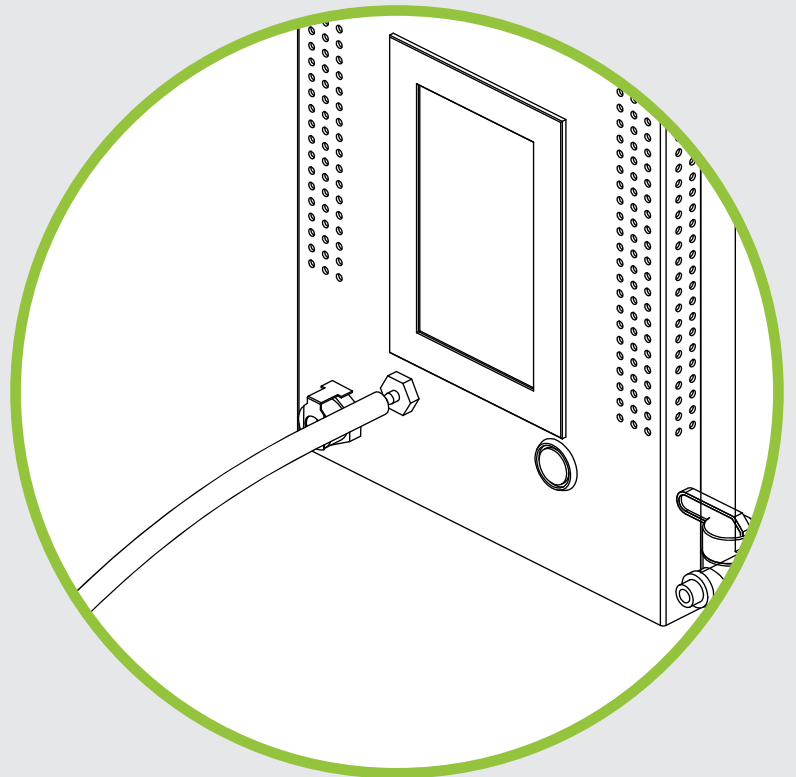

6

You may add 30min or subtract 10min by pressing the following buttons:



7

Feel free to pause the operation at any time by pressing the pause button:

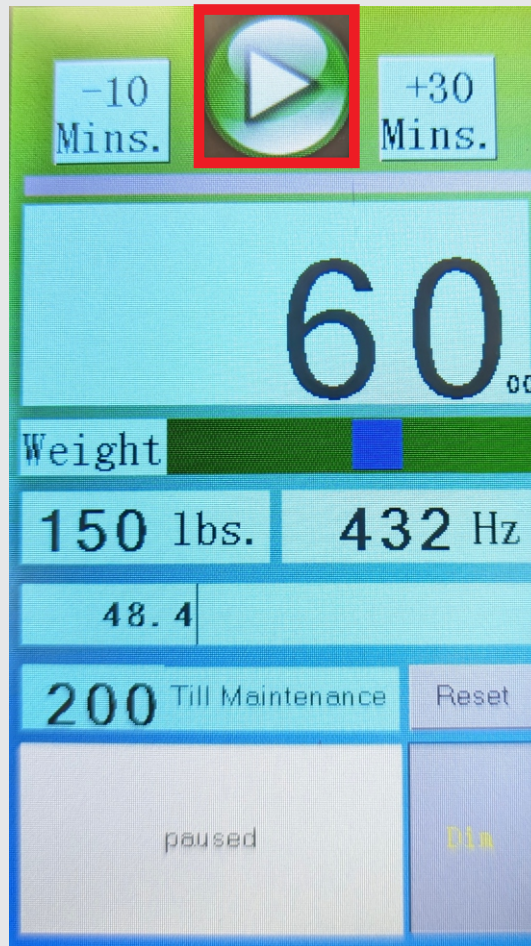

Note

Press the "Dim" button to turn off the screen and the machine's internal lights. You may use this function when using the BG4 machine in dark environments or when sleeping.



No bubbles forming inside the Bubbler

Possible causes:

- If you just turned on your BG4; it may take a couple minutes before you see any bubble formation.
- The lye water tank cap might be loose. Be sure to tighten it firmly.

No gas coming out of the cannula

Possible causes:

- The bubbler tank valve might be open. Make sure the valve goes all the way down.
- If your BG4 has been constantly running for some time it may be in intermittent mode. This happens when the machine gets hot and needs time to cool down. Take a look at your temperature indicator on the screen to check the machine's temperature:



No gas coming out of the diffuser stone

Possible cause:

- The water trap might be plugged in. Disconnect the water trap and make sure your stone diffuser is plugged in directly to the outlet port.

My BG4 machine is on but the screen is off

Possible cause:

- You may have accidentally pressed the “Dim” button which turns off the screen. Turn it on by pressing the same area where the button is located. The mentioned area is shown below:



Perform the following everytime the Lye Water tank drops 1 to 2 inches below the full line:

1

Perform a visual inspection of the lye water tank. If the water level indicator is down by more than an inch proceed to the following step.

2

Take a recipient where you can store the bubbler's water momentarily. Open the bubbler's bottom valve to drain the bubbler's water into said recipient. You may take the tank's cap off so water flows down quicker.

3

Open the lye water tank's cap and fill it with the water you just drained. Make sure to fill the bubbler tank up to just below the full line.

4

Put both the lye water and bubbler tank caps back in place. Be sure to tighten well.

Perform the following every 100 hours:

Note

The bubbler water should be drained and changed out every 100 hours of use without exception.

1

Take your BG4 and place it near a sink or bucket.

2

Open the bubbler's bottom valve to drain the bubbler's tank. You may take the tank's cap off so water flows down quicker

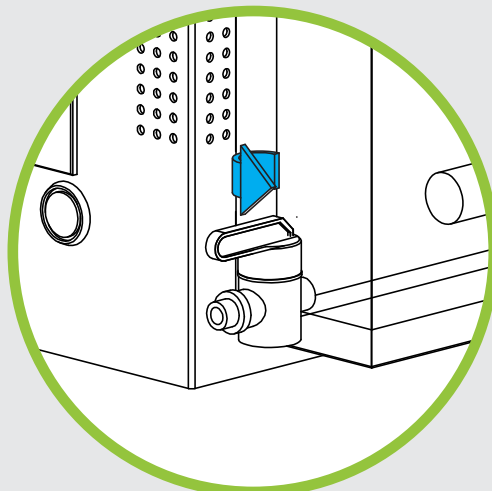
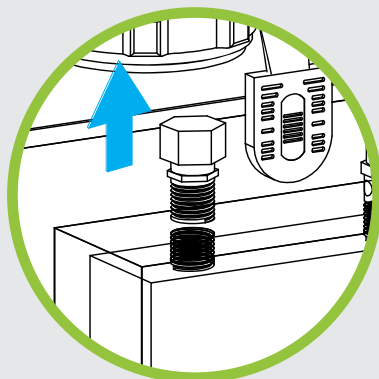

3

Fill up Bubbler tank with distilled water by taking off the tank's cap. Make use of provided funnel. You may pull the tank's valve up so the tank fills up quicker.

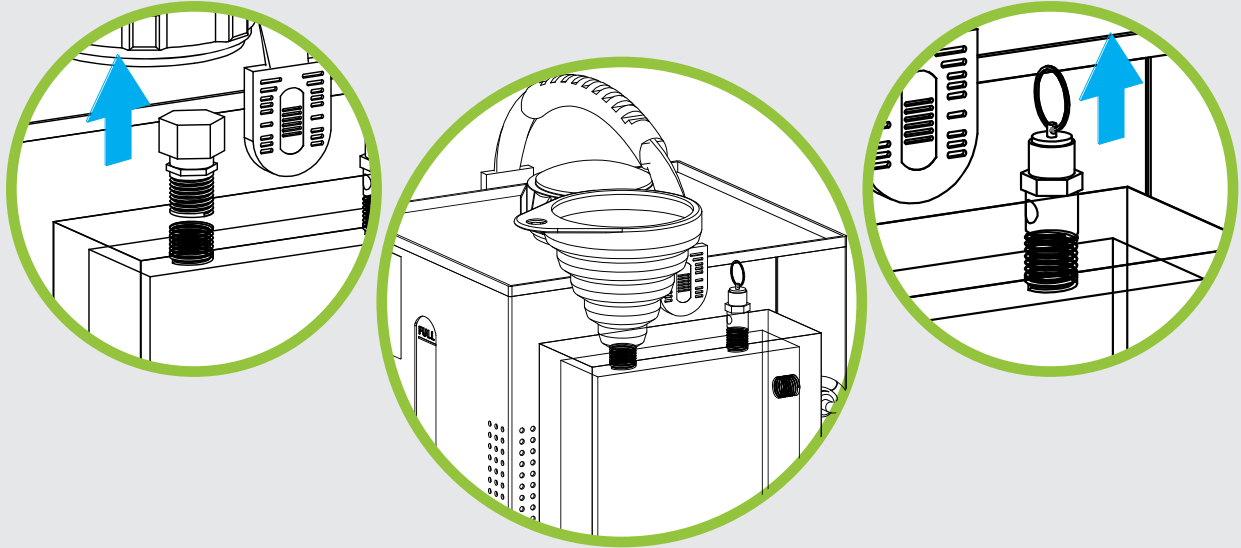

Note

Make sure the tank's valve snaps back down.

4

Put Bubbler Tank cap back in place. Make sure to tighten well.

Perform the following every 200 hours:

The following message will appear on your screen. Follow the instructions on the screen to perform the scheduled maintenance.

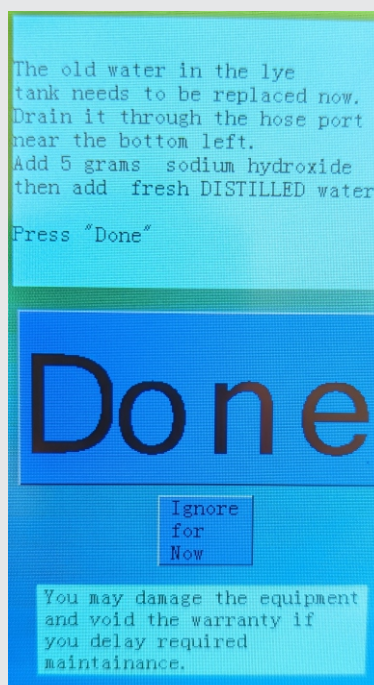

1

Take your BG4 and place it near a sink or bucket.



2

Plug the drain hose to the drain port. Make sure that the end of the drain hose is pointing to the sink or a recipient. You may take the tank's cap off so water flows down quicker. After the tank is completely drain press down on the silver part of the drain port to release the drain fitting.

Note

Water will start flowing as soon as the drain hose is plugged to the drain outlet.

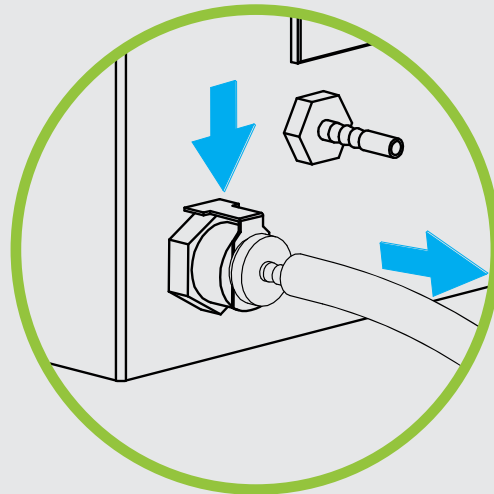
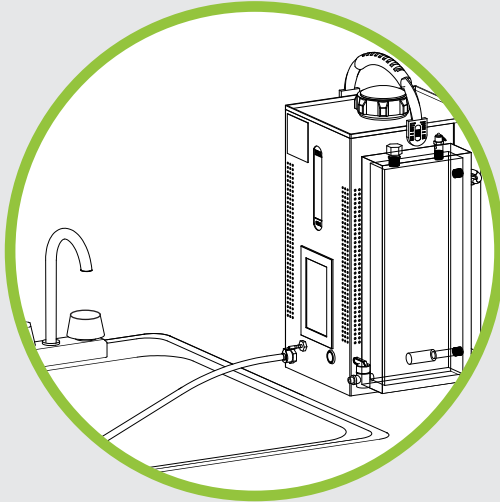

3

Open up the lye water tank cap to deposit two spoon-fulls of lye into the Lye Water Tank. Use provided spoon for measuring. We suggest you also use a small cup to pour the lye into. So it's easier to fill up the spoon.

CAUTION

Lye's contact with skin can cause severe skin burns. Be careful when handling Lye. Use of nitrile gloves is recommended.

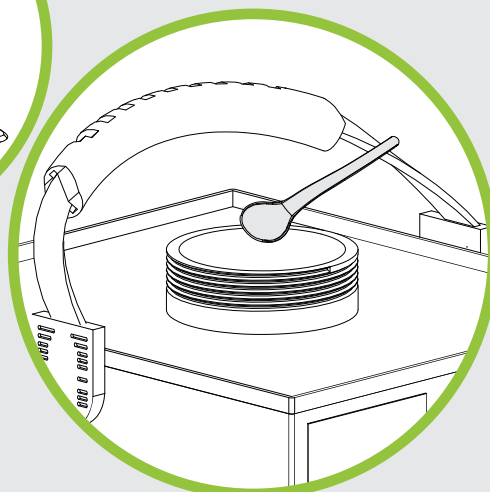

4

Fill up the Lye Water Tank with distilled water using provided funnel. Be careful not to overflow the tank. Pay attention to the water level indicator. Fill up to just below the full line.

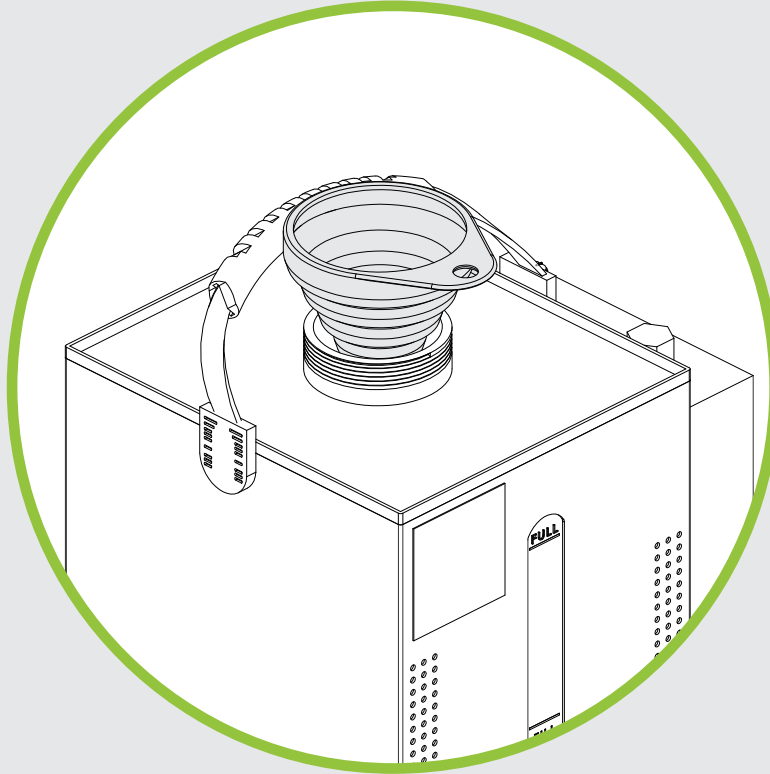

5

Put Lye Water Tank cap back in place. Make sure to tighten well.

6

Open the bubbler's bottom valve to drain the bubbler's tank. You may take the tank's cap off so water flows down quicker

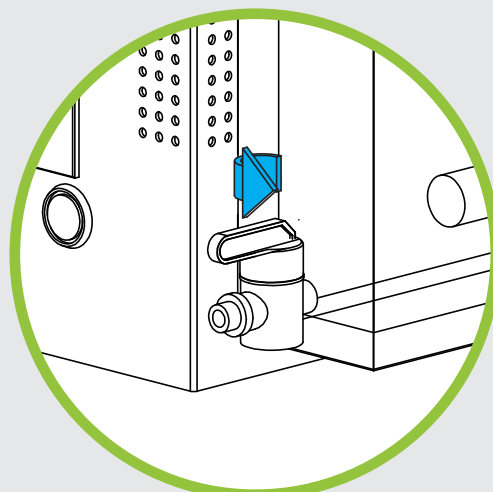
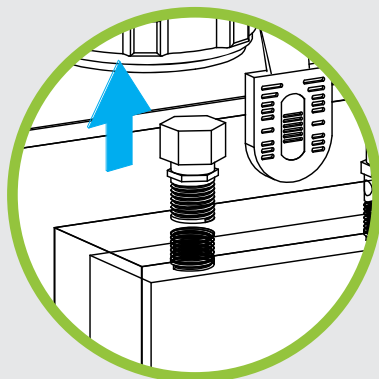

7

Fill up Bubbler tank with distilled water by taking off the tank's cap. Make use of provided funnel. You may pull the tank's valve up so the tank fills up quicker.

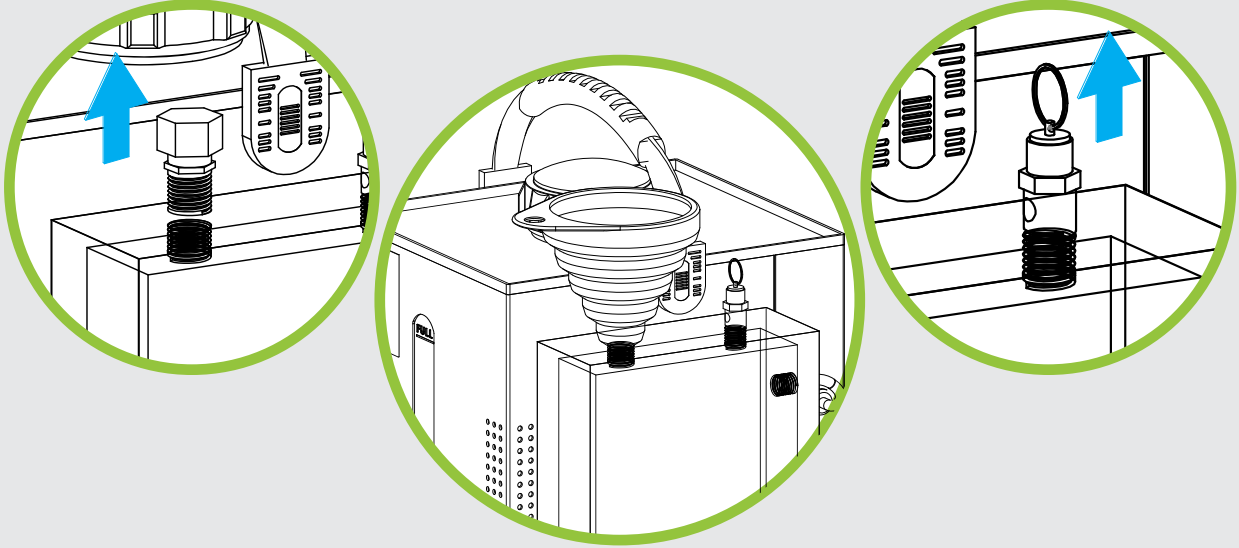

Note
Make sure the tank's valve snaps back down.

8

Put Bubbler Tank cap back in place. Make sure to tighten well.

9

Next time you turn on your BG4: the maintenance message screen will appear one minute after. Click on "Done" to reset your maintenance timer.

Note
You may reset the maintenance timer at any time by pressing the "Reset" button. Do this for any reason you may need to set the maintenance schedule back to 200hrs.

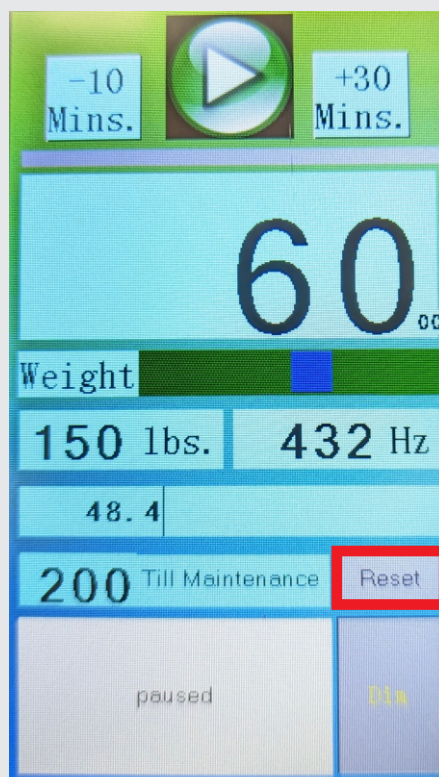

Thanks for purchasing our products at Hydrogen for Health operated by Dell Property LLC.

In order to be eligible for a refund, you have to return the product within 60 calendar days of your purchase. The product must be in the same condition that you receive it and undamaged in any way. You will be charged a 3% restocking fee. This fee pays for our selling fees that are not refunded to use upon your refund.

After we receive your item, our team of professionals will inspect it and process your refund. The money will be refunded to the original payment method you've used during the purchase. For credit card payments it may take 5 to 10 business days for a refund to show up on your credit card statement.

If the product is damaged in any way, or you have initiated the return after 60 calendar days have passed, you will not be eligible for a refund.

Customer is responsible for all shipping costs. You will be charged a shipping fee equal to the amount of the cost to originally ship the product to you.

If anything is unclear or you have more questions feel free to contact our customer support team.



PRODUCT DISCLAIMER

THE FOLLOWING TERMS AND CONDITIONS APPLY TO ALL SALES AND USES OF HYDROGEN4HEALTH PRODUCTS OR SERVICES. PLEASE REVIEW THESE TERMS CAREFULLY. THESE TERMS AND CONDITIONS INCLUDE LIMITED WARRANTIES, DISCLAIMERS OF LIABILITY, AND ARBITRATION PROVISIONS. KEEPING, USING, OR ALLOWING USE OF THE PRODUCT OR SERVICES INDICATES YOUR AGREEMENT TO THESE TERMS. IF YOU DO NOT WISH TO AGREE TO THESE TERMS, YOU HAVE 14 DAYS FROM DATE OF PURCHASE TO RETURN THE UNUSED PRODUCT, SUBJECT TO OUR RETURN POLICY.

Defined Terms: "Hydrogen4Health" means Dell Property LLC, and any and all of its affiliates and/or subsidiaries and/or business agents, servants and employees. "Products" means all equipment, gear, videos or related goods sold on this website or otherwise available by Hydrogen4Health.

Use at own risk: Products sold by Hydrogen4Health include equipment and supplements used in inhaling hydrogen and drinking hydrogen water. Hydrogen4Health strongly encourages and you agree to consult with your physician before using the Products. Please follow all instructions and use the Products only as directed.

Assumption of the Risk: By buying, using, participating in the use of Hydrogen4Health Products, you understand and agree that ingesting hydrogen can be a high risk activity and, to the extent permitted by law, YOU EXPRESSLY AND VOLUNTARILY ASSUME THE RISK OF DEATH OR OTHER PERSONAL INJURY SUSTAINED WHILE PARTICIPATING IN SUCH USE WHETHER OR NOT CAUSED BY THE NEGLIGENCE OR ANY OTHER FAULT OF HYDROGEN4HEALTH including but not limited to equipment malfunction from whatever cause, or any other fault of Hydrogen4Health. Additionally, you agree to indemnify, defend, release and hold Hydrogen4Health harmless from any third party claims arising from such high risk activities or use of any other Hydrogen4Health Product.

Limited Replacement Warranty: Hydrogen4Health warrants to the original purchaser that the Products are free from defects in materials and workmanship for a period of 1 year from date of purchase, provided they have not been subjected to obvious abuse, neglect, misuse or installation. Hydrogen4Health sole liability is limited to repairing or replacing products that are returned within this 1 year period, subject to the terms of our Return Policy.

WARRANTY DISCLAIMER: THE ABOVE STATED WARRANTIES ARE IN LIEU OF ALL OTHER WARRANTIES EXPRESSED OR IMPLIED INCLUDING THE WARRANTIES OF MERCHANTABILITY AND FITNESS FOR A PARTICULAR PURPOSE AND OF ALL OTHER OBLIGATIONS AND LIABILITIES OF HYDROGEN4HEALTH. HYDROGEN4HEALTH NEITHER ASSUMES, NOR AUTHORIZES ANY OTHER PERSON TO ASSUME FOR IT, ANY OTHER LIABILITY IN CONNECTION WITH THE SALE OF THE PRODUCTS. THE ABOVE LIMITED WARRANTIES SHALL NOT APPLY TO ANY PRODUCT THAT HAS BEEN SUBJECT TO ACCIDENT, NEGLIGENCE, ALTERATION, ABUSE, OR MISUSE. THE TERM "ORIGINAL PURCHASER" AS USED IN THIS WARRANTY MEANS THE PERSON TO WHOM THE PRODUCT IS ORIGINALLY SOLD OR SHIPPED TO AS SHOWN ON THE SALES INVOICE. THESE WARRANTIES SHALL APPLY ONLY WITHIN THE BOUNDARIES OF THE UNITED STATES.

Limitation of Liability: As set forth above under the limited warranty provisions, Hydrogen4Health's liability is limited to repair or replacement of its Products which are returned in accordance with its return policy. In no event shall Hydrogen4Health's liability exceed the value of the products sold. Hydrogen4Health shall not be liable for any special or consequential damages that result from the use of any Products. Applicable law may not allow the limitation or exclusion of liability of special or consequential damages so the above limitation or exclusion may not apply to your purchase, but it is intended to be the maximum limitation as permitted by law.

Warning: Use and misuse of Hydrogen4Health Products, sold through Hydrogen4Health's website or otherwise, involves serious risks including injury, disability and death. Purchasers, users and participants assume all risk of injury. Hydrogen4Health cannot and will not be responsible for the misuse or unauthorized and improper use of Hydrogen4Health Products. Hydrogen4Health's Products are intended for use only in connection with the corresponding Hydrogen4Health video. Use of the Products is for personal and domestic use only. Hydrogen4Health Products are not intended for use by children. Anyone under the age of 18, may use the product only under full supervision and care of their parent or guardian who purchased the product. Products sold through Hydrogen4Health are not medical devices and are considered experimental.

Inspect Before Each Use: This product must be inspected for use to ensure it has not been damaged in shipment. If damaged, do not use and immediately return the product to Hydrogen4Health for a replacement.

Applicable Law and Resolution of Disputes: Your order from Hydrogen4Health shall be interpreted and construed in accordance with laws of the State of Utah without regard to its choice of law principles. You agree that any dispute or claim arising out of or in connection with your order or its subject matter or formation (including non-contractual disputes or claims), shall be brought exclusively in the federal or state courts located in Salt Lake City, Utah and for this purpose you hereby submit to the exclusive jurisdiction and venue of such courts. Any cause of action or claim you may have with respect to the purchase of Hydrogen4Health products or any other claim related to the use of products must be commenced within one (1) year after the claim or cause of action arises. Hydrogen4Health's failure to enforce strict performance of any provision of these terms and conditions shall not be construed as a waiver of any provision or right. Neither the course of conduct nor trade practice shall act to modify any of these terms and conditions.

Shipping Policy

We are not responsible both domestically and internationally if your order is stolen from your property delivery address. We can not collect from Insurance if it is confirmed to have been delivered by the Postal Service and stolen from your Mail box or property. We can only respond if the parcel is confirmed to never have been delivered by the Postal Service and deemed lost and therefore never successfully delivered. You are responsible for the security and safe delivery by the Postal Service. We consider our obligation fulfilled and completed once the Postal Authority has given us delivery confirmation to the specified address you put in your order. Your only recourse is to contact your local Postal Authority and discuss your situation with them.

Address

Orem, Utah, 84097

E-mail us

info@hydrogen4health.com

Skype us

Steve Dell

Youtube

Delvis11

Facebook

Hydrogen Water Health

Working Hours

Monday - Friday: 9am -6pm

Weekends and Public Holidays: Closed

